

Quattro 16 shown, some alternatives are NACRA 5.0, 5.2, Condor/Hurricane 4.9, Dart 18 but not Hobie 16 (the hulls have too little buoyancy and the beam mounting is unsuitable)

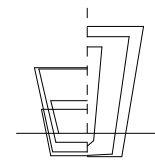

cross sections mainhull

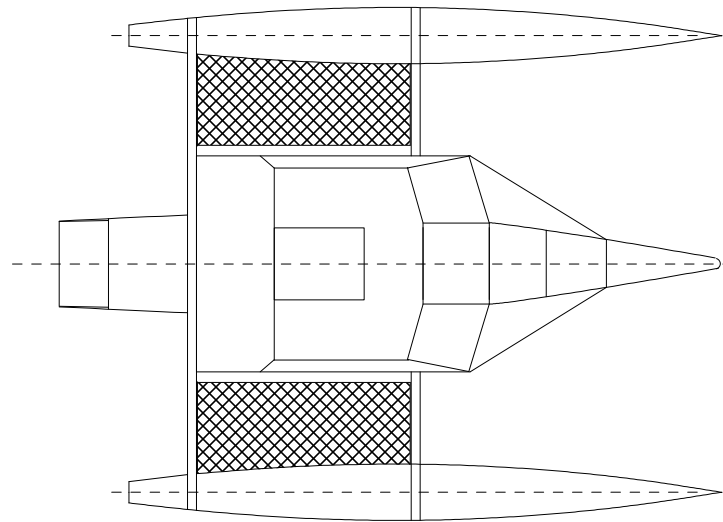
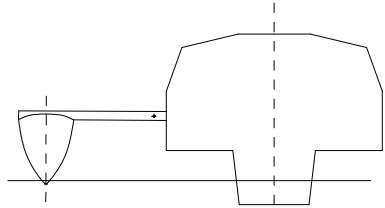

cabin version  
(cabin is removable)

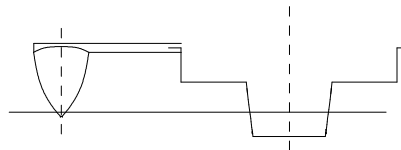

open deck version

LOA 5.5m  
LWL 5.35m  
BOA 4.3m  
Sail Area (Q16)  
Mainsail 13.5sqm  
Jib 5.67sqm (screecher in red optional)  
Empty weight 250kgs  
Loaded weight 600kgs  
Open deck version seats 6  
Cabin version sleeps 2

**Strike 18 trimaran  
beach cat conversion  
using beach cat rig and hulls.**

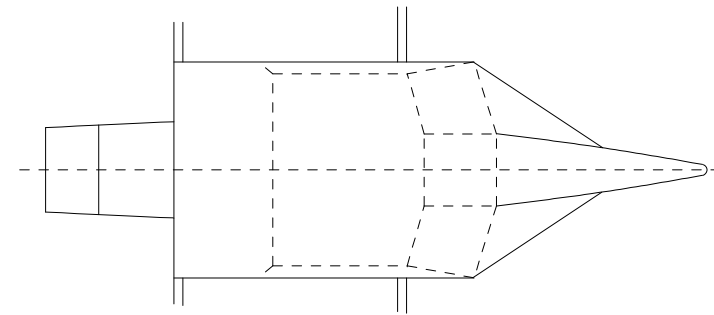

cabin version

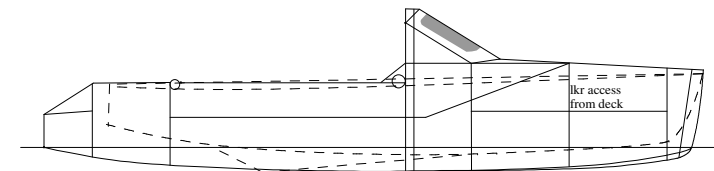
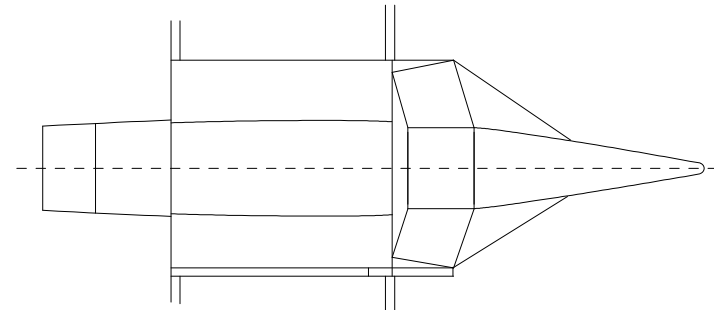
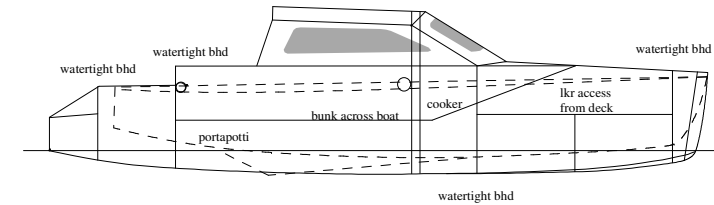

open deck version

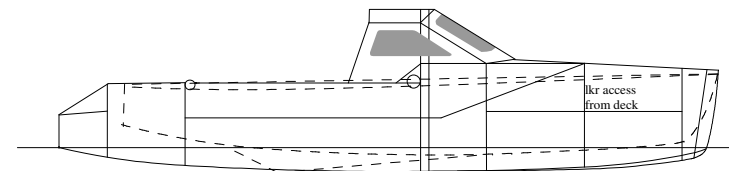

short open back version  
allows room for porta potti and  
small stove behind canvas screen